

D-POC6-LMB-S10-10-3G-* (Steel,350 Bar)

D-POC6-LMB-S10-10-A3G-* (Aluminum,210 Bar)

Dual Pilot-operated Check Valve

DESCRIPTION

Dual pilot-operated check valve inline mounted

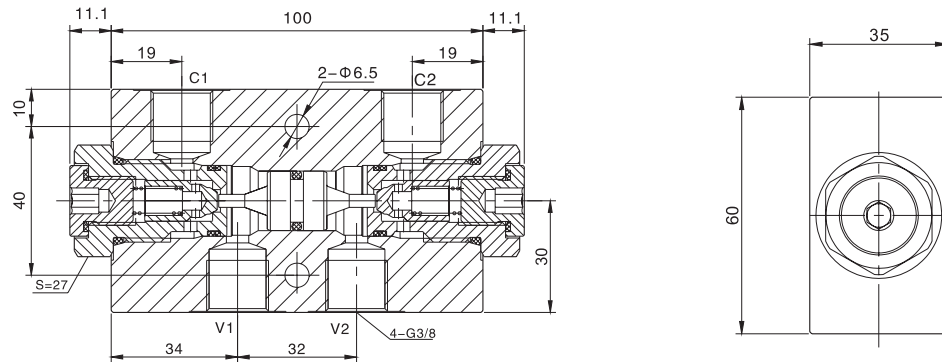

OPERATION

The valve will block from “C1” to “V1” and from “C2” to “V2” .Flow is allowed in the opposite direction when pressure is applied to port “V1” or “V2” . The valve has a 7:1 pilot ratio, so at least 1/7 of the load pressure at port “C1” or “C2” is required at the pilot lines (ports “V1” or “V2”)to open the flow passage to allow flow from ports “C1” or “C2” .

SYMBOL

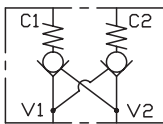

PRESSURE DROP VS.FLOW

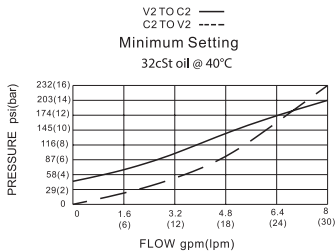

SPECIFICATIONS

Max.Operating Pressure	350bar
Flow	See PRESSURE DROP VS.FLOW graph.
Pilot Ratio	7:1
Internal Leakage	2 drops/min max. at 350 bar
Cracking Pressure	8=8bar; 4.5=4.5bar; 3=3bar
Temperature	-40°F to +250°F(-40°C to +120°C)
Filtration	See page N-1
Fluids	Mineral-based fluids with viscosities of 7.4 to 420 cSt.
Housing Material	Steel & Ductile iron rated to 350bar

TO ORDER

D – POC6 – LMB – S10 – 10 – * 3G – *

1
2
3
4
5
6
7

<p>1 Function D-POC6=Dual Pilot-Operated Check Valve Inline Body</p>	<p>4 Sealing Method of Pilot Piston 00=No O-Ring 10=With O-Ring</p>	<p>6 Port Size 3G=G 3/8 ※Other port sizes are available</p>
<p>2 ConnectionType</p>	<p>5 Housing Material A=Aluminum, 210bar Omit=Steel,350bar</p>	<p>7 Cracking Pressure 8=8bar 4.5=4.5bar 3=3bar</p>
<p>3 Size</p>		